

Dimensions:

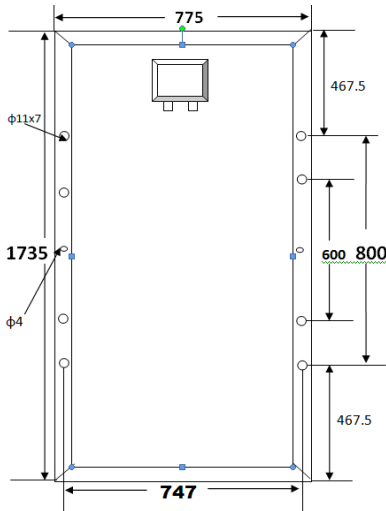

All Dimensions are in mm

RSPL PV Modules are manufactured with the highest A grade materials and features best in class quality and performance. Our Meticulous product design and stringent process control ensures our modules deliver an exceptional high PV yield and stand the test of time.



High Power Density

High conversion efficiency and more power output per square meter



Durability

Certified for Salt Mist Corrosion and PID Resistance



Advanced Glass

High-transmission glass that directs more light on the solar cells



Premium Quality

Built to the most stringent quality standards in the industry.



PID RESISTANT



LINEAR DEGRADATION



OUTPUT EL-TESTED



MINIMAL HOT-SPOT



CONTROLLED GOOD FLOW



HIGHER WEAK LIGHT PERFORMANCE



HIGH YIELD & +VE TOLERANCE



TIER 1 SUPPLIERS



CE
RoHS
COMPLIANT

Certifications :

Qualifications & Certificates
IEC 61215, IEC 61730 -1 & 2, IEC 62804,
IEC 61701, ISO 50001, ISO 18001
ISO 9001, ISO 14001, BIS and
ALMM*

Temperature Co-efficients

NOCT	45±2 °C
Pmp	-0.40 %/°C
Isc	0.07 %/°C
Voc	-0.36 %/°C
Operating Temperature	-40 to +85 °C

System Design :

- Series Fuse Rating (Recommended): 15 A
- Maximum System Voltage: 1000 VDC
- Module Dimension: 1735 x 775 x 35 mm
- Module Weight: 14.70 kg (± 5 %)

Typical Electrical Characteristics at STC

IV parameters are tested at STC (Irradiance of 1000W/m², AM 1.5G and Temperature 25°C)

Mode/Type	(Pmax)	(Vmp)	(Imp)	(Voc)	(Isc)	(Eff)
270 W	270.0	42.53	6.35	51.08	6.65	>20 %

Electrical Parameters Tolerance: ± 3%

Compliance of Simulator readings with an accuracy of class A (±2%)

NOTE :
1. Due to constant product modifications RSPL reserves the right to amend the above specifications without prior notice. The Electrical data given here is for reference purpose only

2. For handling & installation instructions, refer RSPL Installation Manual

3. Please read RSPL warranty documents thoroughly. Please confirm your exact requirements with sales representative while placing your order. All dimensions have standard variation of 3 mm.

*Under Process

**Black and Transparent back sheet and black frame module without IEC certification. 2.8 mm glass also available

Outer Dimensions can have a variance of 3mm